

ORIENTAL MOTOR GENERAL CATALOG



5-PHASE HIGH-TORQUE STEPPING MOTOR AND DRIVER PACKAGE

UPK Series

| | |
|---|-------|
| Standard and High-Speed Types..... | B-108 |
| List of Motor and Driver Combinations | B-117 |
| Wiring Diagram..... | B-118 |
| Description of Input/Output Signals..... | B-119 |

UPK Standard Type

UPK High-Speed Type

- EASY WIRING
- PLC DIRECT
- RE-GENERATION
- PACK-AGE
- AC INPUT

The **UPK** series consists of a high-torque step motor and a high performance driver with vibration control circuitry to minimize mid-frequency resonance.

The **UPK** series can satisfy the requirement of any applications requiring compact, smooth and quiet operation.



■ FEATURES

● Standard Type

The **UPK** standard type is available in three mounting sizes.
 Motor size: 1.65in. (42mm) sq. 2.36in. (60mm) sq.
 3.35in. (85mm) sq.

Holding Torque: 18 oz-in (0.13N·m) — 874 oz-in (6.3N·m)

● High-Speed Type

High-speed type is suitable for applications requiring higher speed operation.

■ ACCESSORIES (Sold separately)

Motor Mounting Bracket

● Motor Mounting Brackets
Page B-298



Clean Damper

● Clean Dampers
Page B-300

Effective at suppressing motor vibration and improving performance.



Flexible Coupling

● Flexible Couplings
Page B-301

MC Motor Couplings



Extension Cable

● Extension Cables
Page B-306

16.4 feet (5m), 32.8 feet (10m), 65.6 feet (20m) long



■ PRODUCT NUMBER CODE

UPK 5 6 9 A □ A

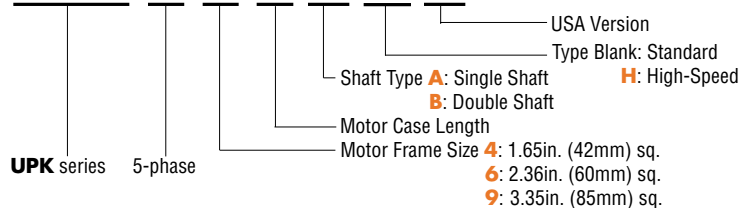

■ SPECIFICATIONS STANDARD TYPE

| Package Model | Single Shaft | UPK543AA | UPK544AA | UPK545AA | UPK564AA | UPK566AA | UPK569AA |
|---------------------------|--|---|-----------------------|-----------------------|------------------------|------------------------|------------------------|
| | Double Shaft | UPK543BA | UPK544BA | UPK545BA | UPK564BA | UPK566BA | UPK569BA |
| Maximum Holding Torque | oz-in | 18 | 24.9 | 33.3 | 58.3 | 115 | 230 |
| | N · m | 0.13 | 0.18 | 0.24 | 0.42 | 0.83 | 1.66 |
| Rotor Inertia | oz-in ² | 0.192 | 0.296 | 0.372 | 0.96 | 1.53 | 3.07 |
| | kg · m ² | 35 × 10 ⁻⁷ | 54 × 10 ⁻⁷ | 68 × 10 ⁻⁷ | 175 × 10 ⁻⁷ | 280 × 10 ⁻⁷ | 560 × 10 ⁻⁷ |
| Rated Current | A/phase | 0.75 | | | 1.4 | | |
| Basic Step Angle | 0.72° | | | | | | |
| Insulation Class | Class B [266°F (130°C)] | | | | | | |
| Power Source | 100V/115V ± 15% AC | | 50/60Hz | 1.1A maximum | 100V/115V ± 15% AC | | 50/60Hz 4.8A maximum |
| Output Current | A/phase | 0.75 | | | 1.4 | | |
| Excitation Mode | <ul style="list-style-type: none"> ● Full Step (4 phase excitation): 0.72°/step ● Half Step (4-5 phase excitation): 0.36°/step | | | | | | |
| Input Signals | Input Signal Circuit | Photocoupler input, Input resistance 220Ω, Input current 20mA maximum Signal voltage Photocoupler ON: +4~+5V, Photocoupler OFF: 0~+0.5V | | | | | |
| | ● Pulse Signal (CW Pulse Signal) | Step command pulse signal (CW step command signal at 2-pulse input mode) Pulse width: 5μs minimum, Pulse rise/fall: 2μs maximum Motor moves when the photocoupler state changes from ON to OFF. | | | | | |
| | ● Rotation Direction Signal (CCW Pulse Signal) | Rotation direction signal, Photocoupler ON: CW, Photocoupler OFF: CCW (CCW step command signal at 2-pulse input mode, Pulse width: 5μs minimum, Pulse rise/fall: 2μs maximum Motor moves when the photocoupler state changes from ON to OFF.) | | | | | |
| Output Signals | ● All Windings Off Signal | When in the "photocoupler ON" state, the current to the motor is cut off and the motor shaft can be rotated manually. When in the "photocoupler OFF" state, the current level set by the RUN switch is supplied to the motor. | | | | | |
| | Output Signal Circuit | Photocoupler- open collector output (emitter common) External use condition DC24V maximum, 10mA minimum | | | | | |
| | ● Excitation Timing Signal | The signal is output every time the excitation sequence returns to the initial stage "0". (Photocoupler: ON) Full step: signal output every 10 pulses, Half step: signal output every 20 pulses | | | | | |
| Functions | ● Overheat Signal | The signal is output when the internal temperature of the driver rises above approximately 176°F (80°C). (Photocoupler: ON) The motor stops automatically if the "Automatic Current Off" function is ON. | | | | | |
| | Functions | Automatic current down, All windings off, Self-test, Pulse input method switch, Step angle switch, Overheat output logic switch. | | | | | |
| Indicators (LED) | Power source input, Pulse input, CW/CCW input, All windings off input, Excitation timing output, Overheat output | | | | | | |
| Driver Cooling Method | Natural Ventilation | | | | | | |
| Weight (Mass) | Motor lb. (kg) | 0.56 (0.25) | 0.67 (0.3) | 0.89 (0.4) | 1.33 (0.6) | 1.77 (0.8) | 2.87 (1.3) |
| | Driver lb. (kg) | 1 (0.45) | | | 1.99 (0.9) | | |
| Insulation Resistance | Motor | 100MΩ minimum under normal temperature and humidity, when measured by a DC500V megger between the motor coils and the motor casing. | | | | | |
| | Driver | 100MΩ minimum under normal temperature and humidity, when measured by a DC500V megger between the case and power input terminal, case and signal input/output terminal, power input terminal and signal input/output terminal. | | | | | |
| Dielectric Strength | Motor | Sufficient to withstand 1.0kV (0.5kV for UPK54 □ type), 60Hz applied between the motor coils and casing for one minute, under normal temperature and humidity. | | | | | |
| | Driver | Sufficient to withstand 1.0kV, 60Hz applied between the case and power input terminal, case and signal input/output terminal power input terminal, and signal input/output terminal for one minute, under normal temperature and humidity. | | | | | |
| Ambient Temperature Range | Motor | +14°F ~ +122°F (-10°C ~ +50°C) | | | | | |
| | Driver | +32°F ~ +122°F (0°C ~ +50°C) | | | | | |

● Maximum holding torque refers to the holding torque at motor standstill when the rated current is supplied to the motor (5 phase excitation). Use this value to compare motor torque performance. When using the motor with the included driver, the driver's "Automatic Current Cutback" function at motor standstill reduces maximum holding torque by approximately 50%.

● The power source input current value represents the maximum current. (The input current varies according to the pulse frequency.)

Note: Do not measure insulation resistance or perform the dielectric strength test while the motor and driver are connected for **UPK54**□ type.

■ SPECIFICATIONS STANDARD TYPE

| Package Model | Single Shaft | UPK596AA | UPK599AA | UPK5913AA |
|---------------------------|---|---|-----------------------|-----------------------|
| | Double Shaft | UPK596BA | UPK599BA | UPK5913BA |
| Maximum Holding Torque | oz-in | 291 | 569 | 874 |
| | N · m | 2.1 | 4.1 | 6.3 |
| Rotor Inertia | oz-in ² | 7.66 | 14.8 | 21.9 |
| | kg · m ² | 1400×10 ⁻⁷ | 2700×10 ⁻⁷ | 4000×10 ⁻⁷ |
| Rated Current | A/phase | 1.4 | | |
| Basic Step Angle | | 0.72° | | |
| Insulation Class | | Class B [(266°F (130°C))] | | |
| Power Source | | 100V/115V±15% AC 50/60Hz 4.8A maximum | | |
| Output Current | A/phase | 1.4 | | |
| Excitation Mode | | <ul style="list-style-type: none"> ● Full Step (4 phase excitation): 0.72°/step ● Half Step (4-5 phase excitation): 0.36°/step | | |
| Input Signals | Input Signal Circuit | Photocoupler input, Input resistance 220Ω, Input current 20mA maximum Signal voltage Photocoupler ON: +4~+5V, Photocoupler OFF: 0~+0.5V | | |
| | ● Pulse Signal (CW Pulse Signal) | Step command pulse signal (CW step command signal at 2-pulse input mode) Pulse width: 5μs minimum, Pulse rise/fall: 2μs maximum Motor moves when the photocoupler state changes from ON to OFF. | | |
| | ● Rotation Direction Signal (CCW Pulse Signal) | Rotation direction signal, Photocoupler ON: CW, Photocoupler OFF: CCW (CCW step command signal at 2-pulse input mode, Pulse width: 5μs minimum, Pulse rise/fall: 2μs maximum Motor moves when the photocoupler state changes from ON to OFF.) | | |
| | ● All Windings Off Signal | When in the "photocoupler ON" state, the current to the motor is cut off and the motor shaft can be rotated manually. When in the "photocoupler OFF" state, the current level set by the RUN switch is supplied to the motor. | | |
| Output Signals | Output Signal Circuit | Photocoupler- open collector output (emitter common) External use condition DC24V maximum, 10mA minimum | | |
| | ● Excitation Timing Signal | The signal is output every time the excitation sequence returns to the initial stage "0". (Photocoupler: ON) Full step: signal output every 10 pulses, Half step: signal output every 20 pulses | | |
| | ● Overheat Signal | The signal is output when the internal temperature of the driver rises above approximately 176°F (80°C). (Photocoupler: ON) The motor stops automatically if the "Automatic Current Off" function is ON. | | |
| Functions | | Automatic current down, All windings off, Self-test, Pulse input method switch, Step angle switch, Overheat output logic switch. | | |
| Indicators (LED) | | Power source input, Pulse input, CW/CCW input, All windings off input, Excitation timing Output, overheat output | | |
| Driver Cooling Method | | Natural Ventilation | | |
| Weight (Mass) | Motor lb. (kg) | 3.75 (1.7) | 6.18 (2.8) | 8.38 (3.8) |
| | Driver lb. (kg) | 1.99 (0.9) | | |
| Insulation Resistance | Motor | 100MΩ minimum under normal temperature and humidity, when measured by a DC500V megger between the motor coils and the motor casing. | | |
| | Driver | 100MΩ minimum under normal temperature and humidity, when measured by a DC500V megger between the case and power input terminal, case and signal input/output terminal, power input terminal and signal input/output terminal. | | |
| Dielectric Strength | Motor | Sufficient to withstand 1.0kV, 60Hz applied between the motor coils and casing for one minute, under normal temperature and humidity. | | |
| | Driver | Sufficient to withstand 1.0kV, 60Hz applied between the case and power input terminal, case and signal input/output terminal power input terminal, and signal input/output terminal for one minute, under normal temperature and humidity. | | |
| Ambient Temperature Range | Motor | +14°F~+122°F (-10°C~+50°C) | | |
| | Driver | +32°F~+122°F (0°C~+50°C) | | |

- Maximum holding torque refers to the holding torque at motor standstill when the rated current is supplied to the motor (5 phase excitation). Use this value to compare motor torque performance. When using the motor with the included driver, the driver's "Automatic Current Cutback" function at motor standstill reduces holding torque by approximately 50%.
- The power source input current value represents the maximum current. (The input current varies according to the pulse frequency.)

HIGH-SPEED TYPE

| Package Model | Single Shaft | UPK569AHA | UPK596AHA | UPK599AHA | UPK5913AHA |
|---------------------------|--|---|-----------------------|-----------------------|-----------------------|
| | Double Shaft | UPK569BHA | UPK596BHA | UPK599BHA | UPK5913BHA |
| Maximum Holding Torque | oz-in | 230 | 291 | 569 | 874 |
| | N · m | 1.66 | 2.1 | 4.1 | 6.3 |
| Rotor Inertia | oz-in ² | 3.07 | 7.66 | 14.8 | 21.9 |
| | kg · m ² | 560×10 ⁻⁷ | 1400×10 ⁻⁷ | 2700×10 ⁻⁷ | 4000×10 ⁻⁷ |
| Rated Current | A/phase | 2.8 | | | |
| Basic Step Angle | 0.72° | | | | |
| Insulation Class | Class B [(266°F (130°C))] | | | | |
| Power Source | 100V/115V±15% AC 50/60Hz 7.5A maximum | | | | |
| Output Current | A/phase | 2.8 | | | |
| Excitation Mode | <ul style="list-style-type: none"> ● Full Step (4 phase excitation): 0.72°/step ● Half Step (4-5 phase excitation): 0.36°/step | | | | |
| Input Signals | Input Signal Circuit | Photocoupler input, Input resistance 220Ω, Input current 20mA maximum Signal voltage Photocoupler ON: +4~+5V, Photocoupler OFF: 0~+0.5V | | | |
| | ● Pulse Signal (CW Pulse Signal) | Step command pulse signal (CW step command signal at 2-pulse input mode) Pulse width: 5μs minimum, Pulse rise/fall: 2μs maximum Motor moves when the photocoupler state changes from ON to OFF. | | | |
| | ● Rotation Direction Signal (CCW Pulse Signal) | Rotation direction signal, Photocoupler ON: CW, Photocoupler OFF: CCW (CCW step command signal at 2-pulse input mode, Pulse width: 5μs minimum, Pulse rise/fall: 2μs maximum Motor moves when the photocoupler state changes from ON to OFF.) | | | |
| | ● All Windings Off Signal | When in the "photocoupler ON" state, the current to the motor is cut off and the motor shaft can be rotated manually. When in the "photocoupler OFF" state, the current level set by the RUN switch is supplied to the motor. | | | |
| Output Signals | Output Signal Circuit | Photocoupler- open collector output (emitter common) External use condition DC24V maximum, 10mA minimum | | | |
| | ● Excitation Timing Signal | The signal is output every time the excitation sequence returns to the initial stage "0". (Photocoupler: ON) Full step: signal output every 10 pulses, Half step: signal output every 20 pulses | | | |
| | ● Overheat Signal | The signal is output when the internal temperature of the driver rises above approximately 176°F (80°C). (Photocoupler: ON) The motor stops automatically if the "Automatic Current Off" function is ON. | | | |
| Functions | Automatic current down, All windings off, Self-test, Pulse input method switch, Step angle switch, Overheat output logic switch. | | | | |
| Indicators (LED) | Power source input, Pulse input, CW/CCW input, All windings off input, Excitation timing output, Overheat output | | | | |
| Driver Cooling Method | Internal Fan | | | | |
| Weight (Mass) | Motor lb. (kg) | 2.87 (1.3) | 3.75 (1.7) | 6.18 (2.8) | 8.38 (3.8) |
| | Driver lb. (kg) | 2.65 (1.2) | | | |
| Insulation Resistance | Motor | 100MΩ minimum under normal temperature and humidity, when measured by a DC500V megger between the motor coils and the motor casing. | | | |
| | Driver | 100MΩ minimum under normal temperature and humidity, when measured by a DC500V megger between the case and power input terminal, case and signal input/output terminal, power input terminal and signal input/output terminal. | | | |
| Dielectric Strength | Motor | Sufficient to withstand 1.0kV, 60Hz applied between the motor coils and casing for one minute, under normal temperature and humidity. | | | |
| | Driver | Sufficient to withstand 1.0kV, 60Hz applied between the case and power input terminal, case and signal input/output terminal power input terminal, and signal input/output terminal for one minute, under normal temperature and humidity. | | | |
| Ambient Temperature Range | Motor | +14°F~+122°F (-10°C~+50°C) | | | |
| | Driver | +32°F~+122°F (0°C~+50°C) | | | |

- Maximum holding torque refers to the holding torque at motor standstill when the rated current is supplied to the motor (5 phase excitation). Use this value to compare motor torque performance. When using the motor with the included driver, the driver's "Automatic Current Cutback" function at motor standstill reduces maximum holding torque by approximately 50%.
- The power source input current value represents the maximum current. (The input current varies according to the pulse frequency.)

SPEED vs. TORQUE CHARACTERISTICS

fs: Maximum Starting Pulse Rate

Standard Type

UPK543BA

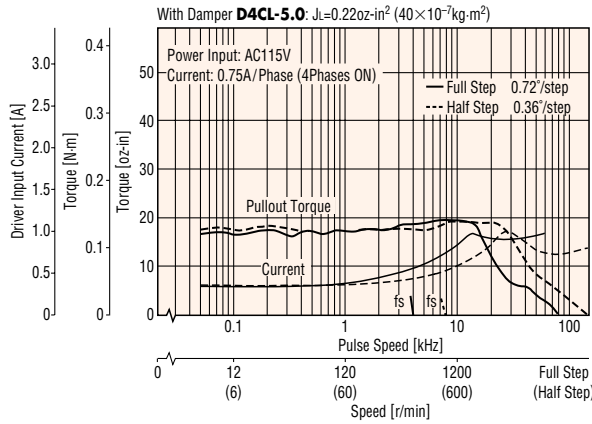

UPK564BA

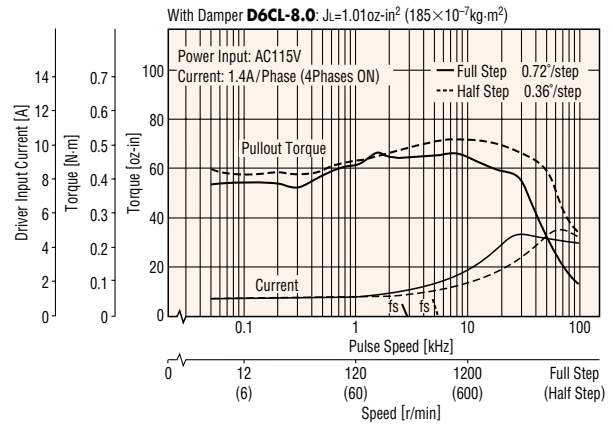

UPK544BA

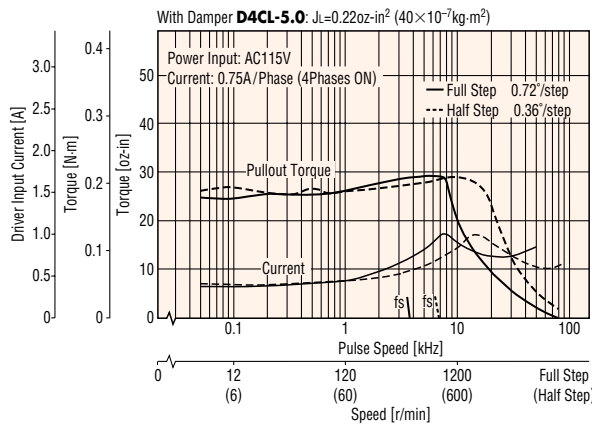

UPK566BA

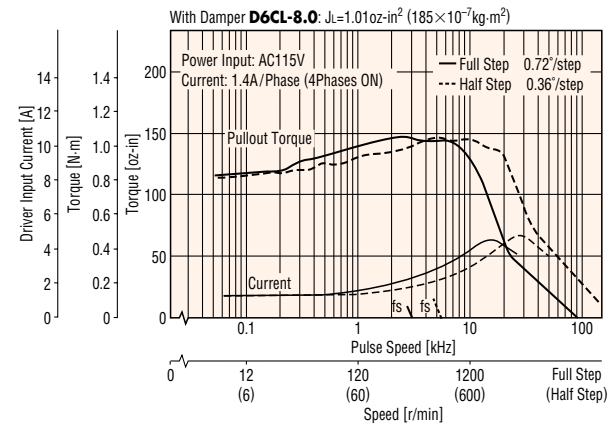

UPK545BA

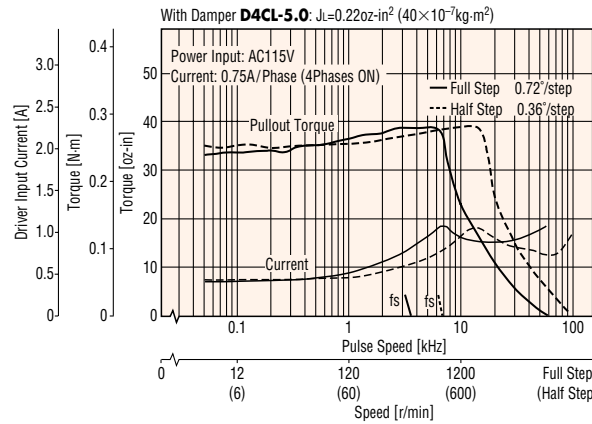

UPK569BA

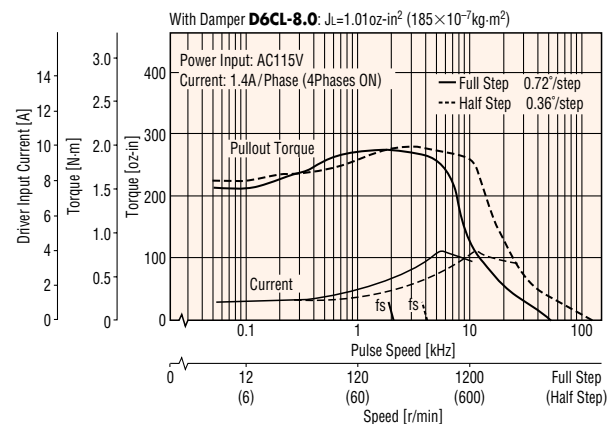

Note:

- Pay attention to heat dissipation from the motor and driver. The motor will produce a considerable amount of heat under certain conditions. Be sure to keep the temperature of the motor case under 212°F (100°C).
- When using the motor with the dedicated driver, the driver's "Automatic Current Cutback" function at motor standstill reduces maximum holding torque by approximately 50%.

● **Standard Type**

UPK596BA

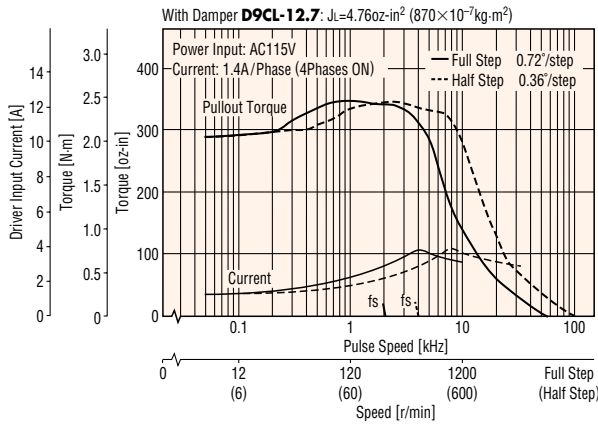

UPK599BA

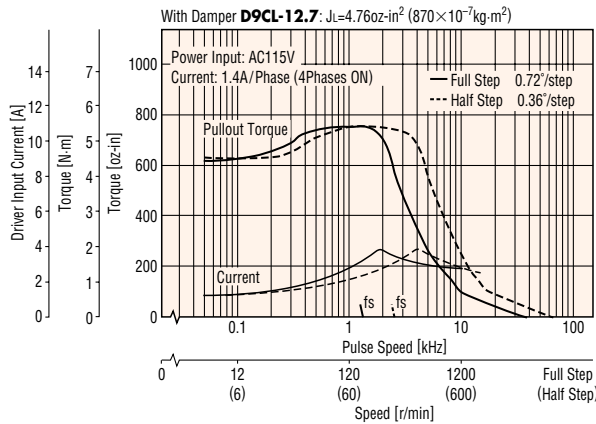

UPK5913BA

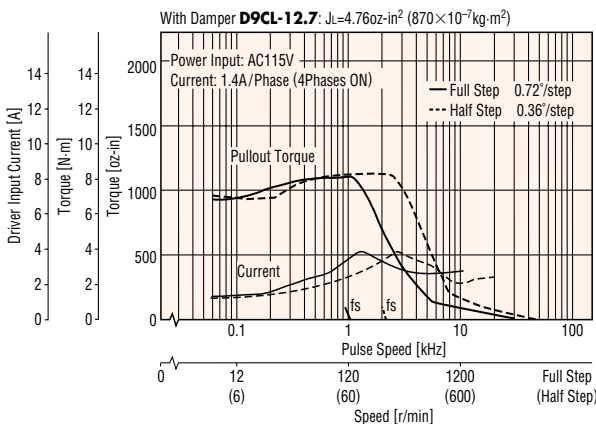

● **High-Speed Type**

UPK569BHA

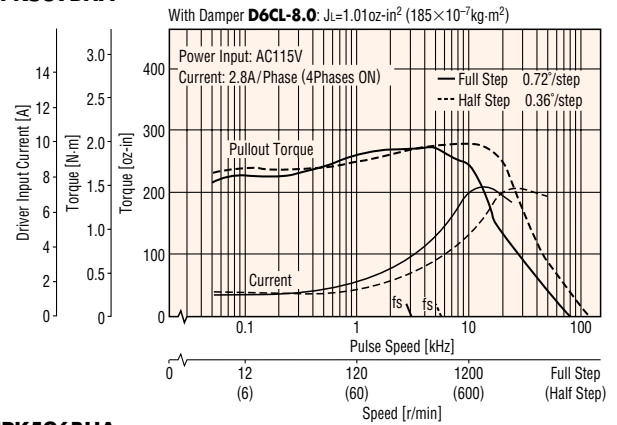

UPK596BHA

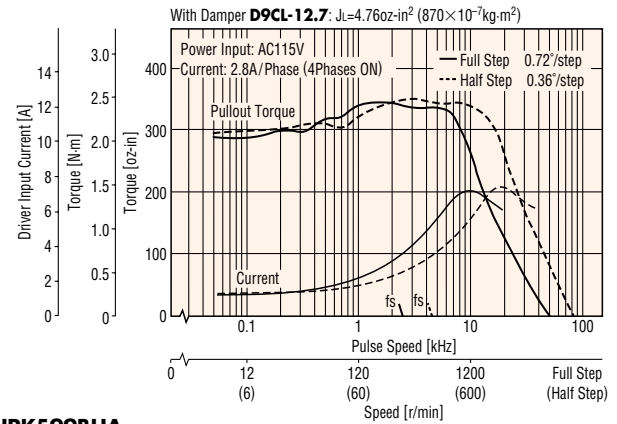

UPK599BHA

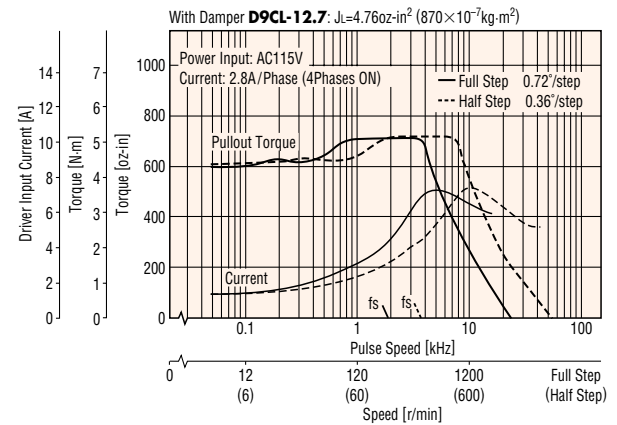

UPK5913BHA

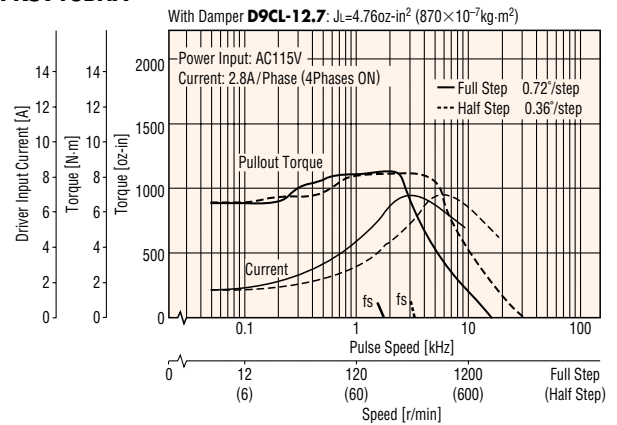

Note:

- Pay attention to heat dissipation from the motor and driver. The motor will produce a considerable amount of heat under certain conditions. Be sure to keep the temperature of the motor case under 212°F (100°C).
- When using the motor with the dedicated driver, the driver's "Automatic Current Cutback" function at motor standstill reduces maximum holding torque by approximately 50%.

DIMENSIONS scale 1/4, unit = inch (mm)

Motor (Standard and High-Speed Type)

UPK543AA (Single shaft)

Motor Model: PK543AUA Weight 0.56 lb. (Mass 0.25kg)

UPK543BA (Double shaft)

Motor Model: PK543BUA Weight 0.56 lb. (Mass 0.25kg)

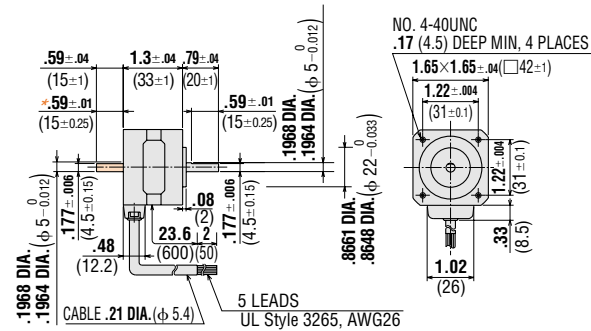

* .59±.01(15±0.25) indicates the length of milling on motor shaft.

UPK544AA (Single shaft)

Motor Model: PK544AUA Weight 0.67 lb. (Mass 0.3kg)

UPK544BA (Double shaft)

Motor Model: PK544BUA Weight 0.67 lb. (Mass 0.3kg)

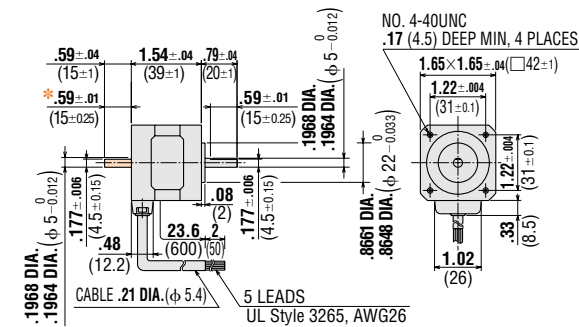

* .59±.01(15±0.25) indicates the length of milling on motor shaft.

UPK545AA (Single shaft)

Motor Model: PK545AUA Weight 0.89 lb. (Mass 0.4kg)

UPK545BA (Double shaft)

Motor Model: PK545BUA Weight 0.89 lb. (Mass 0.4kg)

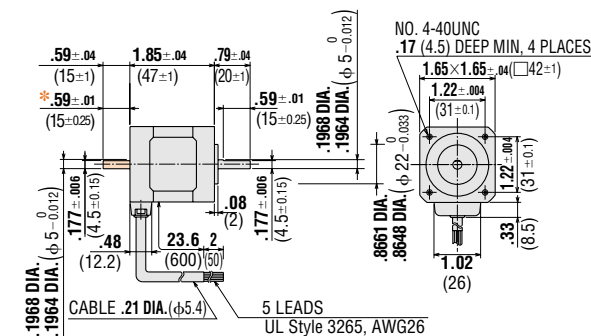

* .59±.01(15±0.25) indicates the length of milling on motor shaft.

• These external appearance drawings are for double shaft models. For a single shaft, ignore the colored areas.

See page B-36 for information on motor installation.

UPK564AA (Single shaft)

Motor Model: PK564AUA Weight 1.33 lb. (Mass 0.6kg)

UPK564BA (Double shaft)

Motor Model: PK564BUA Weight 1.33 lb. (Mass 0.6kg)

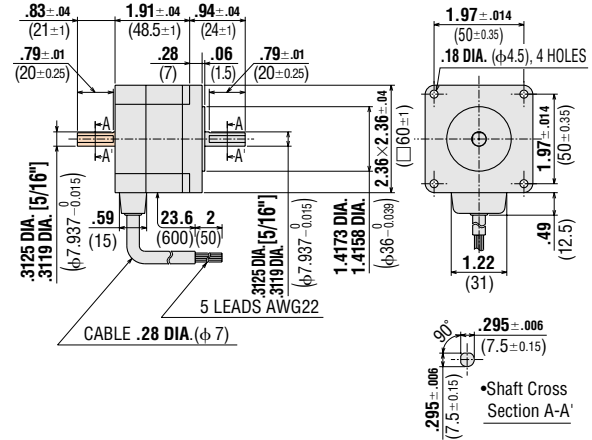

UPK566AA (Single shaft)

Motor Model: PK566AUA Weight 1.77 lb. (Mass 0.8kg)

UPK566BA (Double shaft)

Motor Model: PK566BUA Weight 1.77 lb. (Mass 0.8kg)

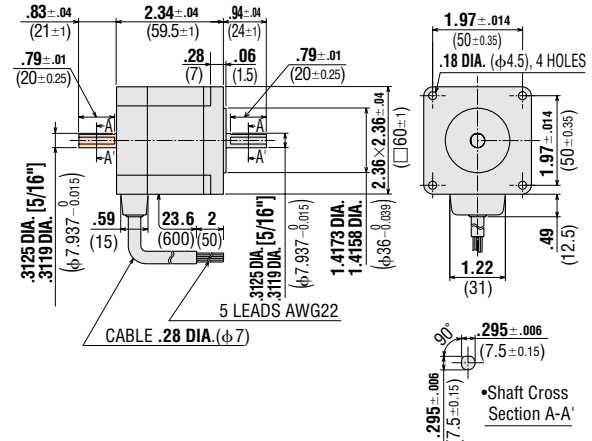

UPK569AA (Single shaft)

Motor Model: PK569AUA Weight 2.87 lb. (Mass 1.3kg)

UPK569BA (Double shaft)

Motor Model: PK569BUA Weight 2.87 lb. (Mass 1.3kg)

UPK569AHA (Single shaft)

Motor Model: PK569AUHA Weight 2.87 lb. (Mass 1.3kg)

UPK569BHA (Double shaft)

Motor Model: PK569BUHA Weight 2.87 lb. (Mass 1.3kg)

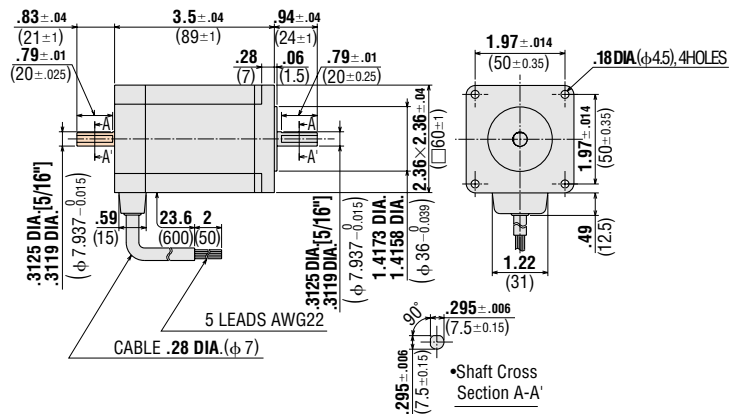

UPK596AA (Single shaft)
 Motor Model: PK596AUA Weight 3.75 lb. (Mass 1.7kg)
UPK596BA (Double shaft)
 Motor Model: PK596BUA Weight 3.75 lb. (Mass 1.7kg)

UPK596AHA (Single shaft)
 Motor Model: PK596AUHA Weight 3.75 lb. (Mass 1.7kg)
UPK596BHA (Double shaft)
 Motor Model: PK596BUHA Weight 3.75 lb. (Mass 1.7kg)

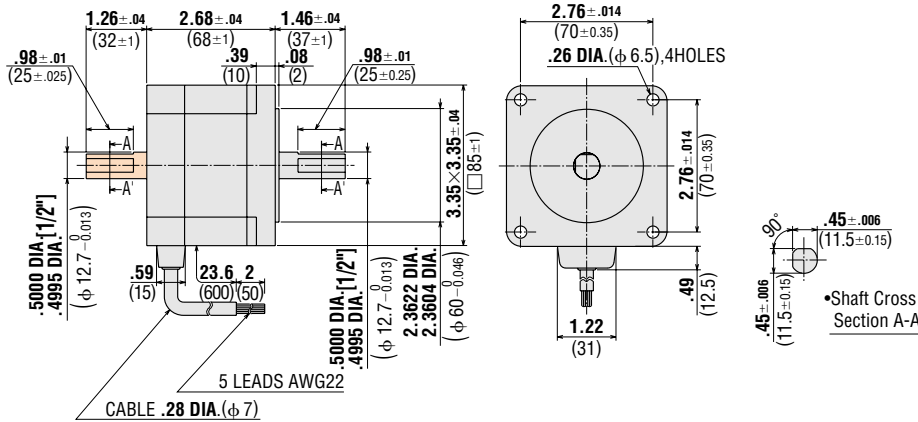

UPK599AA (Single shaft)
 Motor Model: PK599AUA Weight 6.18 lb. (Mass 2.8kg)
UPK599BA (Double shaft)
 Motor Model: PK599BUA Weight 6.18 lb. (Mass 2.8kg)

UPK599AHA (Single shaft)
 Motor Model: PK599AUHA Weight 6.18 lb. (Mass 2.8kg)
UPK599BHA (Double shaft)
 Motor Model: PK599BUHA Weight 6.18 lb. (Mass 2.8kg)

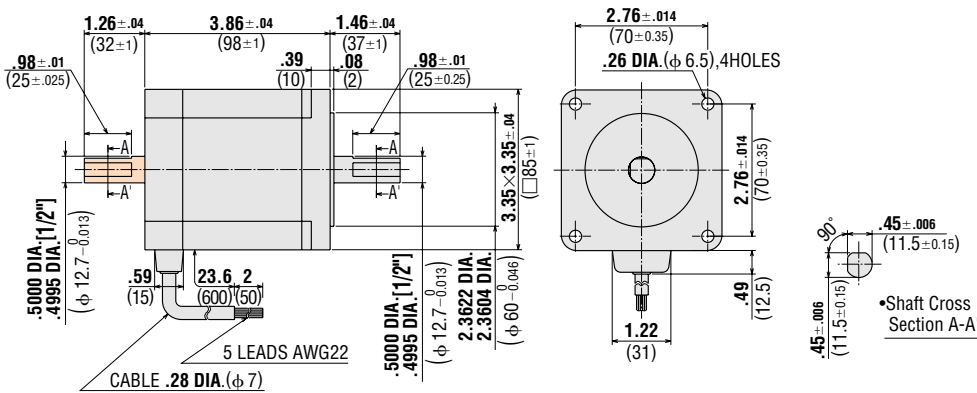

UPK5913AA (Single shaft)
 Motor Model: PK5913AUA Weight 8.38 lb. (Mass 3.8kg)
UPK5913BA (Double shaft)
 Motor Model: PK5913BUA Weight 8.38 lb. (Mass 3.8kg)

UPK5913AHA (Single shaft)
 Motor Model: PK5913AUHA Weight 8.38 lb. (Mass 3.8kg)
UPK5913BHA (Double shaft)
 Motor Model: PK5913BUHA Weight 8.38 lb. (Mass 3.8kg)

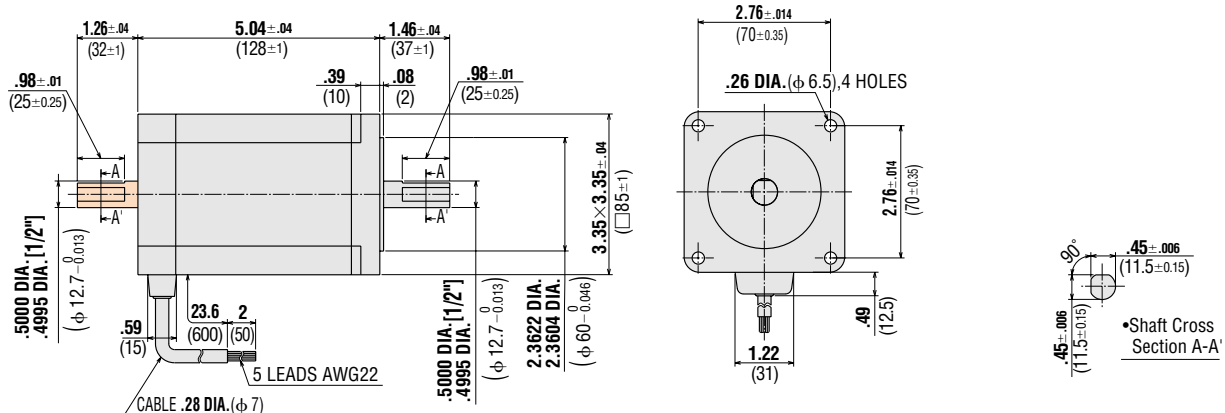

• These external appearance drawings are of double shaft models. For a single shaft, ignore the colored areas.

See page B-36 for information on motor installation.

High-Speed Type

For **UPK569□HA**, **UPK596□HA**,
UPK599□HA, **UPK5913□HA**

Driver: UDK5128NA Weight 2.65 lb. (Mass 1.2kg)

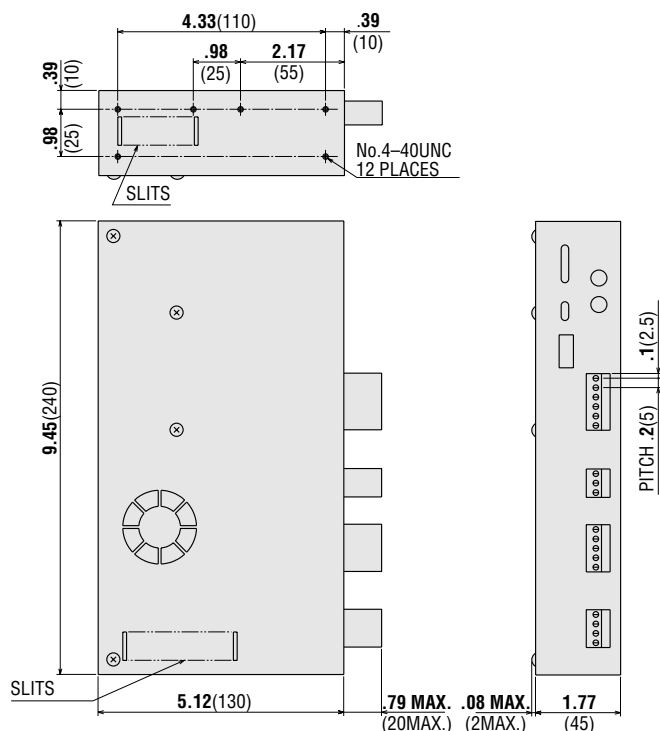

● Mounting tab A (included)

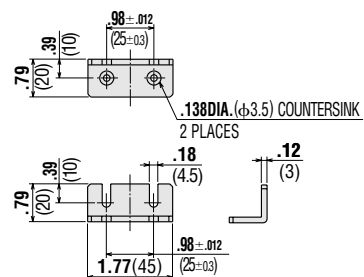

● Mounting tab B (included)

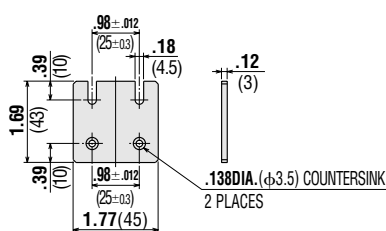

See page B-38 for information on driver installation.

List of Motor and Driver Combinations

| Type | Package model | Stepping motor | | Driver |
|------------|---|---|-----------------|-----------|
| | | Model | Current A/phase | Model |
| STANDARD | UPK543□A UPK544□A UPK545□A | PK543□UA PK544□UA PK545□UA | 0.75 | UDK5107NA |
| | UPK564□A UPK566□A UPK569□A UPK596□A UPK599□A UPK5913□A | PK564□UA PK566□UA PK569□UA PK596□UA PK599□UA PK5913□UA | 1.4 | UDK5114NA |
| HIGH-SPEED | UPK569□HA UPK596□HA UPK599□HA UPK5913□HA | PK569□UHA PK596□UHA PK599□UHA PK5913□UHA | 2.8 | UDK5128NA |

Enter **A** (single shaft) or **B** (double shaft) in the □ within the model numbers.

■ WIRING DIAGRAM

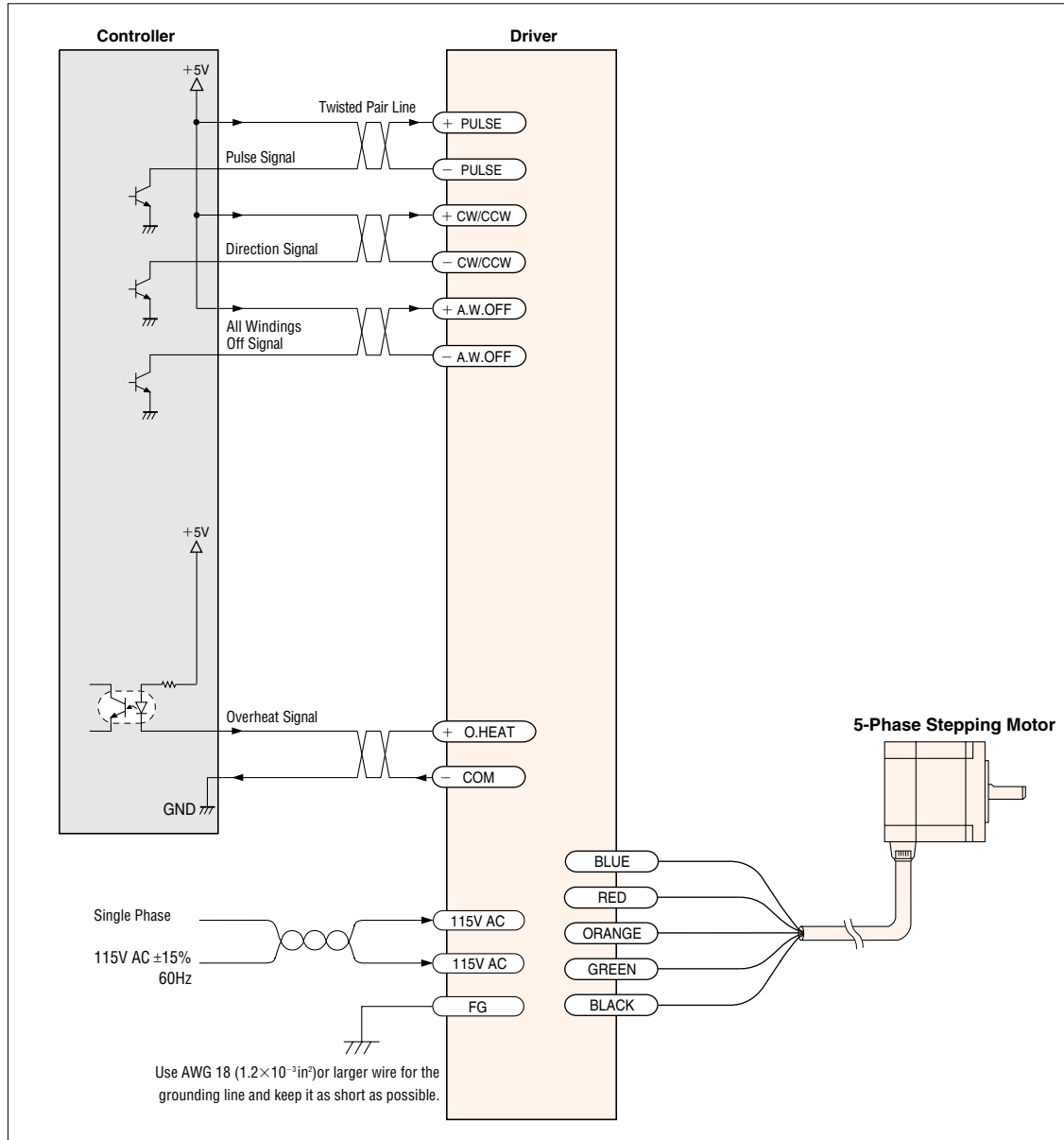

■ Power Supply

Use a power supply that can supply sufficient input current. When power supply capacity is insufficient, a decrease in motor output can cause the following malfunctions:

- Motor does not rotate properly at high-speed (insufficient torque)
- Motor startup and stopping is slow.

Note:

- Use twisted-pair wire of $3.1 \times 10^{-4} \text{ in}^2$ (0.2 mm^2) or thicker and 6.6 feet (2m) or less in length for the signal line.
- Use wire $7.8 \times 10^{-4} \text{ in}^2$ (0.5 mm^2) or thicker for motor lines (when extended) and power supply lines, and use $1.2 \times 10^{-3} \text{ in}^2$ (0.75 mm^2) or thicker for the wire for the grounding line.
- Use spot grounding for the grounding of the driver and external controller.
- Signal lines should be kept at least 3.94 inch (10cm) away from power lines (power supply lines and motor lines). Do not bind the signal line and power line together.

Do not turn on the power or operate the motor until confirming that the auto-diagnosis switch is set to NORM. If it is set to TEST, there is a danger that the motor will start rotating as soon as the power to the driver is turned on.

Use open collector transistors (sink type) for the signal output sections of the controller.

DESCRIPTION OF INPUT/OUTPUT SIGNALS

1. Pulse Input

Input circuit and sample connection

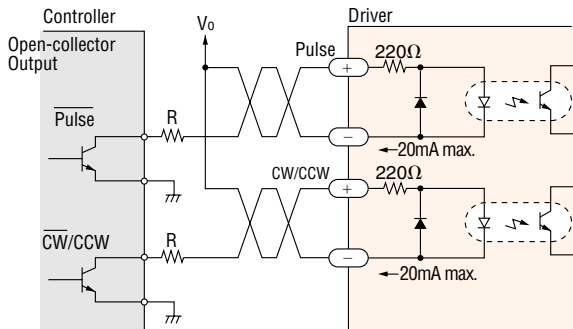

Keep the voltage between DC 5V and DC 24V.
When voltage is equal to DC 5V, external resistance (R) is not necessary. When voltage is above DC 5V, connect external resistance (R) and keep the input current below 20mA.

1. 1-Pulse Input Mode

Pulse Signal

"Pulse" signal is input to the pulse signal terminal. When the photocoupler state changes from "ON" to "OFF", the motor rotates one step. The direction of rotation is determined by the following rotation direction signal.

Rotation Direction Signal

The "Rotation Direction" signal is input to the rotation direction signal input terminal. A "photocoupler ON" signal input commands a clockwise direction rotation. A "photocoupler OFF" signal input commands a counterclockwise direction rotation.

2. 2-Pulse Input Mode

CW Pulse Signal

When the photocoupler state changes from "ON" to "OFF", the motor rotates one step in the clockwise direction.

CCW Pulse Signal

When the photocoupler state changes from "ON" to "OFF", the motor rotates one step in the counterclockwise direction.

CW and CCW refer to clockwise and counterclockwise direction respectively, from a reference point of facing the motor output shaft.

Pulse Waveform Characteristics

(Photocoupler state corresponding the input pulse)

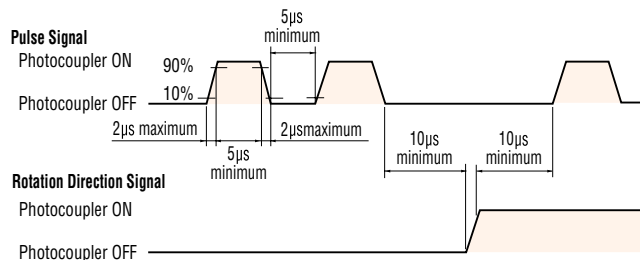

The shaded area indicates when the photocoupler diode is ON. The motor moves when the photocoupler state changes from ON to OFF as indicated by the arrow.

Pulse Signal Characteristics

- The pulse voltage is 4~5V in the "photocoupler ON" state, and 0~0.5V in the "photocoupler OFF" state.
- Input pulse signals should have a pulse width over 5μs, pulse rise/fall below 2μs, and a pulse duty below 50%.
- Keep the pulse signal at "photocoupler OFF" when no pulse is being input.

- The minimum interval time when changing rotation direction is 10μs. This value varies greatly depending on the motor type, pulse frequency and load inertia. It may be necessary to increase this time interval.
- In 1-pulse input mode, leave the pulse signal at rest ("photocoupler OFF") when changing rotation directions.

2. A.W.OFF (All Windings Off) Input

Input circuit and sample connection

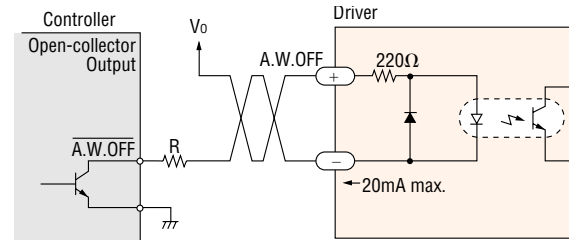

Keep the voltage between DC 5V and DC 24V.
When voltage is equal to DC 5V, external resistance (R) is not necessary. When voltage is above DC 5V, connect external resistance (R) and keep the input current below 20mA.

When the "All Windings Off" signal is in the "photocoupler ON" state, the current to the motor is cut off and motor torque is reduced to zero. The motor output shaft can then be rotated freely by hand.

When the "All Windings Off" signal is in the "photocoupler OFF" state, the motor holding torque is proportional to the current set by the current adjustment rotary switches. During motor operation be sure to keep the signal in the "photocoupler OFF" state.

This signal is used when moving the motor by external force or manual home position is desired. If this function is not needed, it is not necessary to connect this terminal.

Switching the "All Windings Off" signal from "photocoupler ON" to "photocoupler OFF" does not alter the excitation sequence.

When the motor shaft is manually adjusted with the "All Windings Off" signal input, the shaft will shift up to $\pm 3.6^\circ$ from the position set after the "All Windings Off" signal is released.

Manual Setting of the Home Position

Input the "All Windings Off" signal, set the motor to the desired position, then release the "All Windings Off" signal.

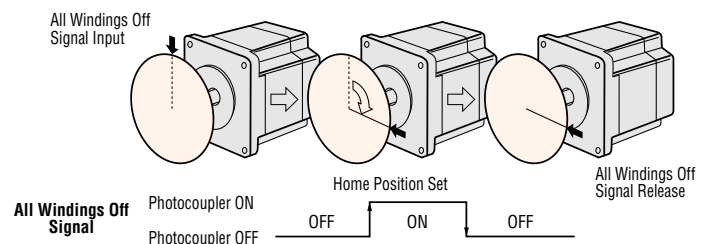

3. O.HEAT (Overheat) Output

■ Output circuit and sample connection

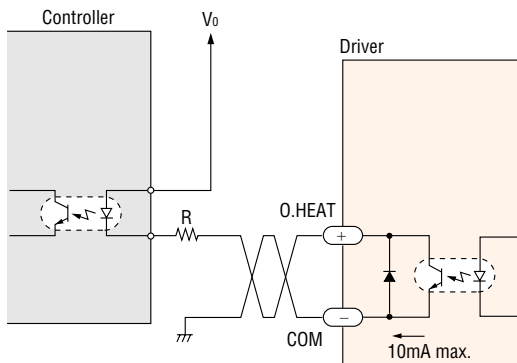

Keep the voltage between DC 5V and DC 24V.
Keep the current below 10mA. If the current exceeds 10mA, connect external resistance (R).

The "Overheat" signal is output to protect the driver from heat damage if the internal temperature of the driver rises above 176°F (80°C).
When connected as shown in the example connection, the signal will be "photocoupler OFF" during normal conditions, and "photocoupler ON" when the temperature exceeds above 176°F (80°C).
When the "Overheat" signal is output, turn the driver power OFF, then adjust the operating conditions (ambient temperature, driver/controller settings, etc.), or use a fan to cool the driver. After taking appropriate measures, turn the power ON. Turning the power ON will reset the "Overheat" signal and release the "Automatic Current Off" condition.

■ Relation to the "Automatic Current Off" function switch

1. When set to ACD

- The "Overheat" signal is output when the internal temperature of the driver exceeds 176°F (80°C) during operation.
- Regardless of any pulse signals input, motor excitation will cause the shaft to be free and the motor will come to a natural stop.

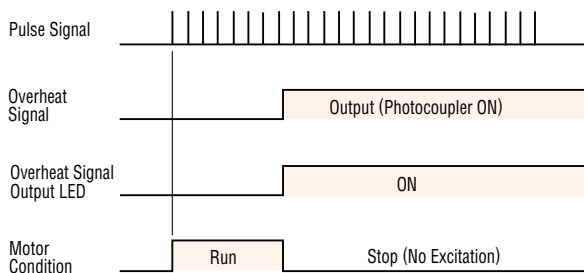

2. When set to OFF

- The "Overheat" signal is output when the internal temperature of the driver exceeds 176°F (80°C) during operation.
- The motor will continue to run regardless of the "Overheat" signal output.

