

### Parallel Port Interface PPI-04.

The PPI-04 module is a buffered interface connecting up to four single-axis step motor drivers to a single parallel port of the PC.

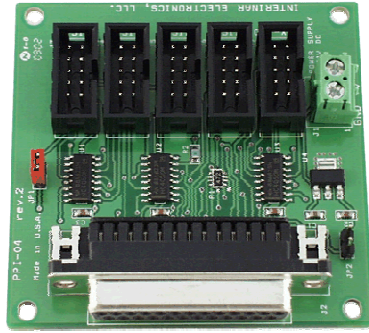

Figure 1 Parallel Port Interface PPI-04

#### Supported Stepper Drivers

- BSD-02
- BSD-02LH
- BSD-01v2

Other drivers with 5V logic inputs can be connected indirectly.

#### Power Supply

There is no need for external power supply if connected to supported drivers. To use this feature the first driver must be connected to J3 (X-Axis) while JP1-ON and JP2- OFF.

External power supply must be used for applications with unsupported drivers and/or when AUX connections are required. External power supply 7 to 24V connects to J1, while JP2-ON and JP1-OFF.

#### Cables

- PC to PPI-04 – use DB25 M-M, straight-thru, fully-wired p/n: PC305-06M DB25 M-M
- PPI-04 to BSD – use ribbon, 10-conductor p/n: FC10-14I

Table 1 Header J3, J4, J5, J6 (see Figure 2)

Pin #	Pin Description
1	ENABLE - output, active-low. Connect to ENA input of the driver.
2	+5V DC – positive supply voltage input. <b>J3 ONLY</b> . NOT CONNECTED on J4, J5, J6.
3	NOT CONNECTED.
4	NOT CONNECTED.
5	DIRECTION - output. Connect to DIR input of the driver.
6	STEP – output. Connect to STEP input of the driver.
7	NOT CONNECTED.
8	NOT CONNECTED.
9	NOT CONNECTED.
10	GND - ground.

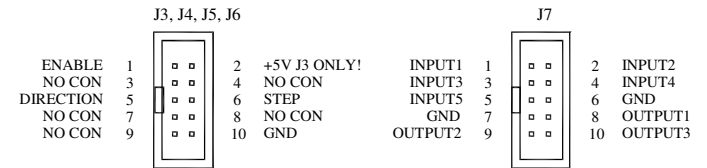

Figure 2. 10-Pin Header J2

Table 2 Header J7 (see Figure 2)

Pin #	Pin Description
1	INPUT1 – input. Auxiliary input may be used to connect external signals to LPT port.
2	INPUT2 – input. Auxiliary input may be used to connect external signals to LPT port.
3	INPUT3 – input. Auxiliary input may be used to connect external signals to LPT port.
4	INPUT4 – input. Auxiliary input may be used to connect external signals to LPT port.
5	INPUT5 – input. Auxiliary input may be used to connect external signals to LPT port.
6	GND - ground.
7	GND - ground.
8	OUTPUT1 – output. Auxiliary output may be used to connect external devices to LPT port.
9	OUTPUT2 – output. Auxiliary output may be used to connect external devices to LPT port.
10	OUTPUT3 – output. Auxiliary output may be used to connect external devices to LPT port.

Table 3 Connector J2

Pin #	Pin Description
1	ENABLE - output, active-low. When logic-low all outputs of the stepper drivers are enabled.
2	STEP X – output. A low-to-high transition advances the motor one increment.
3	DIRECTION X- output. Low or High determines the direction of the rotation of the motor X.
4	STEP Y – output. A low-to-high transition advances the motor one increment.
5	DIRECTION Y- output. Low or High determines the direction of the rotation of the motor Y.
6	STEP Z – output. A low-to-high transition advances the motor one increment.
7	DIRECTION Z- output. Low or High determines the direction of the rotation of the motor Z.
8	STEP A – output. A low-to-high transition advances the motor one increment.
9	DIRECTION A- output. Low or High determines the direction of the rotation of the motor A.
10	INPUT1 – input. Auxiliary input may be used to connect external signals to LPT port.
11	INPUT2 – input. Auxiliary input may be used to connect external signals to LPT port.
12	INPUT3 – input. Auxiliary input may be used to connect external signals to LPT port.
13	INPUT4 – input. Auxiliary input may be used to connect external signals to LPT port.
14	OUTPUT1 – output. Auxiliary output may be used to connect external devices to LPT port.
15	INPUT5 – input. Auxiliary input may be used to connect external signals to LPT port.
16	OUTPUT2 – output. Auxiliary output may be used to connect external devices to LPT port.
17	OUTPUT3 – output. Auxiliary output may be used to connect external devices to LPT port.
18	GND - signal ground.
19	GND - signal ground.
20	GND - signal ground.
21	GND - signal ground.
22	GND - signal ground.
23	GND - signal ground.
24	GND - signal ground.
25	GND - signal ground.

Table 4 Power Supply Selection

JP 1	JP 2	
ON	OFF	(default) Power from BSD driver connected to J3 X-Axis
OFF	ON	Power from external power supply connected to J1, 7 to 24V DC, min 200mA,

The PPI-04 can be mounted using four holes located in the corners of the circuit board. Use plastic standoffs or spacers at least ¼” high to support the board. To fasten the board use #4 or 3mm screws.

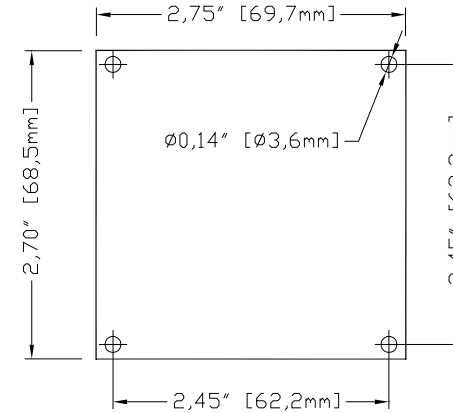
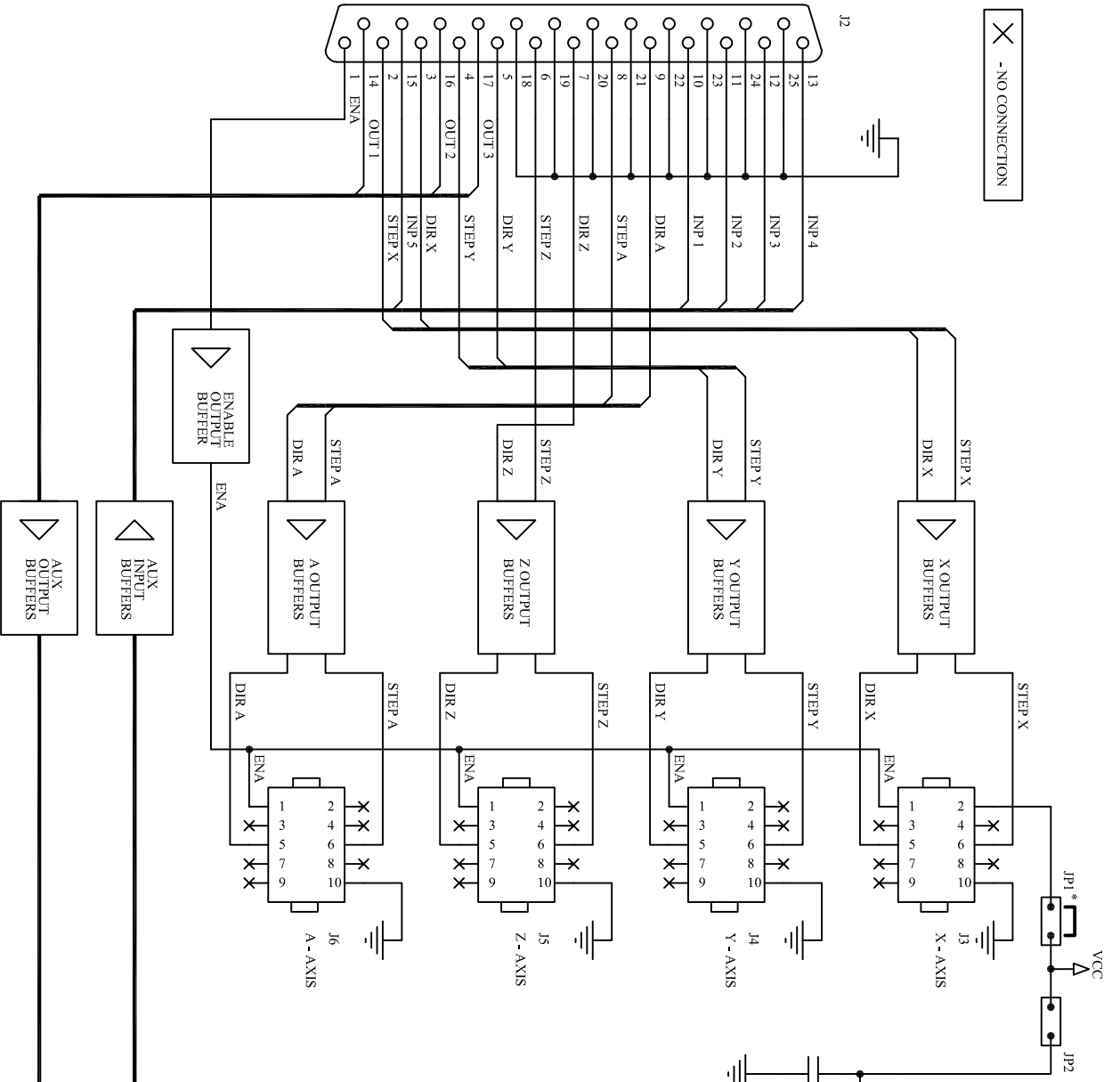

Figure 3 Dimensions and Mounting Holes

Table 5 Electrical Characteristics at Ta=+25°C

Characteristic	Symbol	Test Condition	Limit			Unit	
			Min	Typ	Max		
Supply Voltage	from J3	V <sub>CC</sub>	JP1-ON		5		V
	from J1	V <sub>PS</sub>	JP2-ON	7		24	V
Aux Input Logic Voltage	V <sub>IN(1)</sub>			3.5	-	-	V
	V <sub>IN(0)</sub>			-	-	1.5	V
Aux Input Voltage	V <sub>IN</sub>			0	-	5	V
Max Aux Input Current	I <sub>IK</sub>	per Input		-	-	±15	mA
Aux Output Logic Voltage	V <sub>OUT(1)</sub>	TTL Loads		3.7	-	-	V
	V <sub>OUT(0)</sub>			-	-	0.4	V
Aux Output Voltage	V <sub>OUT</sub>			0	-	5	V
Max Aux Output Current	I <sub>OK</sub>	per Output		-	-	±15	mA
Operating Temperature Range	-			-20	-	+85	°C

Block diagram and connection details - please refer to drawing nr P0310.09



✗ -NO CONNECTION

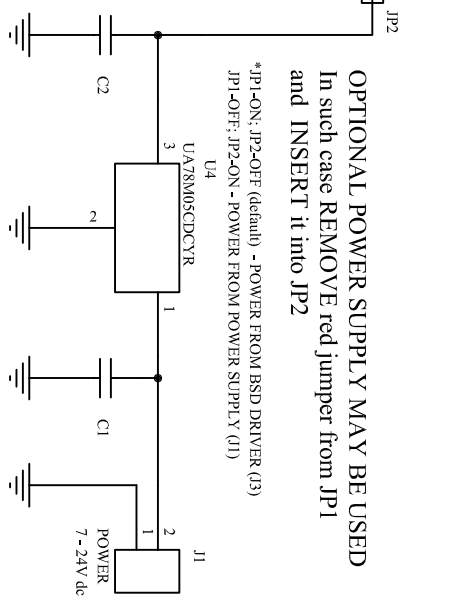

**OPTIONAL POWER SUPPLY MAY BE USED**  
 In such case REMOVE red jumper from JP1  
 and INSERT it into JP2

\*JP1-ON: JP2-OFF (default) - POWER FROM BSD DRIVER (G3)  
 JP1-OFF: JP2-ON - POWER FROM POWER SUPPLY (J1)

INPUT VOLTAGE ALLOWED ON  
 J7 PINS INP1 - INP5 IS  
 MIN - 0V MAX - 5V

OUTPUT VOLTAGE AVAILABLE ON  
 J7 PINS OUT1 - OUT3 IS  
 MIN - 0V MAX - 5V

- 1- ENABLE
- 2- STEP X
- 3- DIR X
- 4- STEP Y
- 5- DIR Y
- 6- STEP Z
- 7- DIR Z
- 8- STEP A
- 9- DIR A
- 10- INP1
- 11- INP2
- 12- INP3
- 13- INP4
- 14- OUT1
- 15- INP5
- 16- OUT2
- 17- OUT3
- 18- GND
- 19- GND
- 20- GND
- 21- GND
- 22- GND
- 23- GND
- 24- GND
- 25- GND

We have used our best effort in preparing this document. We make no representations or warranties with respect to the accuracy or completeness of the contents of this document and specifically disclaim any implied warranties of fitness for a particular purpose. We shall not be liable for any loss of profit or any other commercial damages.

REV	REV NOTE	DATE	CAT	SCALE	FILE NAME	SHEET	DATE
			54	not to scale	PP1-04-R2.dwg	1	03-09-2009

	<b>Interimar</b> ELECTRONICS <a href="http://www.interimar.com">http://www.interimar.com</a> <a href="mailto:support@interimar.com">support@interimar.com</a>	TITLE <b>Parallel Port Interface</b> DWG# <b>PP1-04-R2 Block Schematic</b>	SHEET <b>1</b>
DWG <b>M.V.</b>	DATE <b>03-09-2009</b>	FILE NAME <b>PP1-04-R2.dwg</b>	DATE <b>03-09-2009</b>

